

DATA SHEET

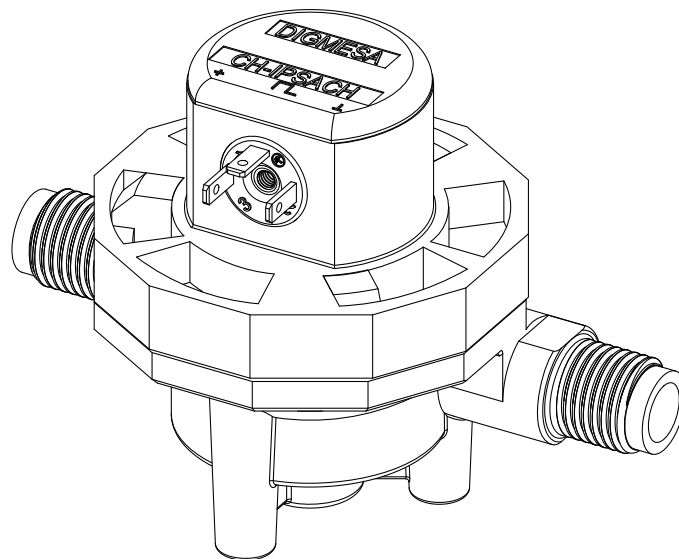

DIGMESA[®]
CHOOSE THE ORIGINAL

FFG 60 PVDF
Part number: 934-2360

Digmesa AG, Keltenstrasse 31, CH-2563 Ipsach / Switzerland

Phone +41 (32) 332 77 77, Fax +41 (32) 332 77 88

www.digmesa.com

Version 04 FFG 60 PVDF 934-2360 GB Page 1-4

General Description

The FFG 60 Flowmeter is a general-purpose device; its working range can be individually defined according to the nozzle size. It is employed for measuring, regulating or metering and guarantees most precise measurement of fluid quantities. In addition, a pulse generator integrated into the flowmeter guarantees a practically unlimited useful life.

Special features: able to withstand high temperatures, good resistance to chemicals. Compact design, great working range. Inlet and outlet are freely selectable.

Employed in the semiconductor (wafer polishing) sector due to the high purity of materials used.

Approvals / Standards

EN55014-1:00+A1:01+A2:02, EN61000-6-3:01+A11:04, IEC61000-6-3:06(ed.2.0), EN61000-3-2:06, IEC61000-3-2:05(ed.3.0), EN61000-3-3:95+A1:01+A2:05, IEC61000-3-3:94+A1:01+A2:05(Cons.ed 1.2), EN55014-2:97+A1:01, EN61000-6-1:01, IEC61000-6-1:05(ed.2)



Material:

Housing:	PVDF
Bearing pin:	PCTFE
Nozzle:	PTFE
O-ring:	FPM (Viton) EPDM / Kalrez on request
Turbine:	PVDF 4 Magnets 2 Magnets on request
Magnets:	Keramik Sr Fe O (not in contact with the medium)
Flat cap spinell:	Spinell blue (MgO 3.5 Al ₂ O ₃)

Technical data:

Flow rate:	0.35 - 15.75 l/min
Continuous operation:	< 500 rpm of the turbine
Measuring accuracy:	+/- 2.0% *
Repetition:	< +/- 0.25%
Temperature range:	-10°C to +100°C 14°F to 212°F
Pressure range:	5.5 bar at 20°C 79 psi / 68°F
Mounting position:	Horizontal *
Nozzle size:	Ø 6.0mm

Electrical connection ratings:

Power supply:	3.8-24 VDC
Consumption:	< 20.1mA
Signal connection:	Open collector NPN
Signal voltage:	0 VDC GND (Sättigung < 0.7 V)
Signal load:	max. 20 mA
Leakage current:	max. 10 µA
Connections:	3Pin- AMP 2.8 x 0.8 mm
Signal:	Rechteck-Ausgang
Duty Cycle:	~ 50%

* Accuracy in the linear range for individually calibrated equipment

Abmessungen in mm:

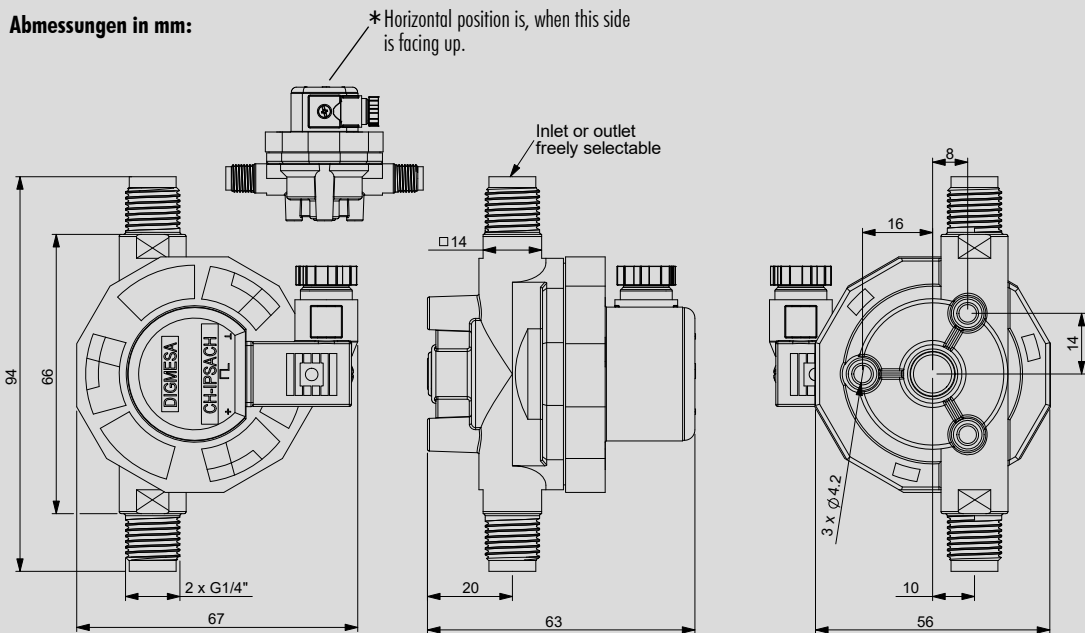

Included in the delivery:

3-pin valve connector
Item number: 941-0010-3

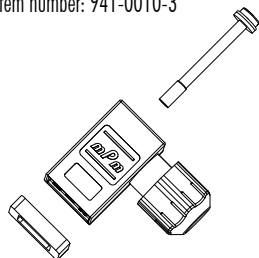

We reserve the right to make modifications in the interests of technical progress.

RESISTANCE

Special regulations which must be complied with by the flowmeter manufacturer apply to each country, e.g. CE, NSF, FDA and SK. The various media flowing through the flowmeter differ from application to application. You are advised to enquire with the medium manufacturer as to whether the entire installation and the flowmeter are resistant to the medium itself (see Material)!

ELECTRONIC

DIGMESA electronic circuitry is always designed for operation with DIGMESA flowmeters. Please note the following if connecting to other electronic circuitry:

- The flowmeter does not supply an output voltage but switches the signal terminal to 0 V ground (actuated) or leaves it open (non-actuated)
- There must be a pull-up resistor between power supply + and signal depending on electronic circuitry!

Version 04 FFG 60 PVDF 934-2360 GB Page 2-4

Interface Connection: Examples Open Collector

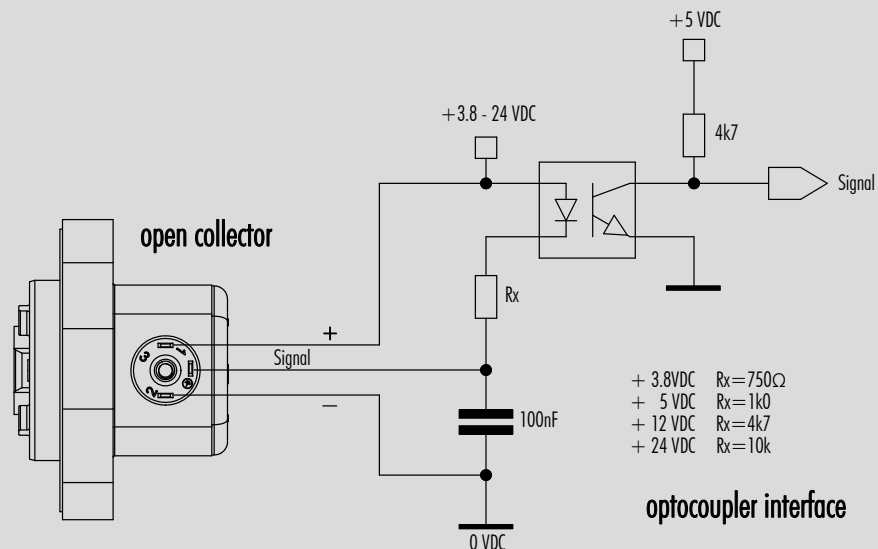
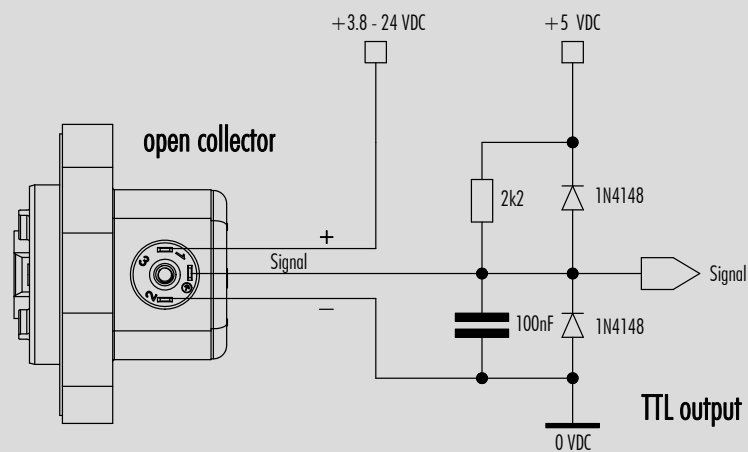
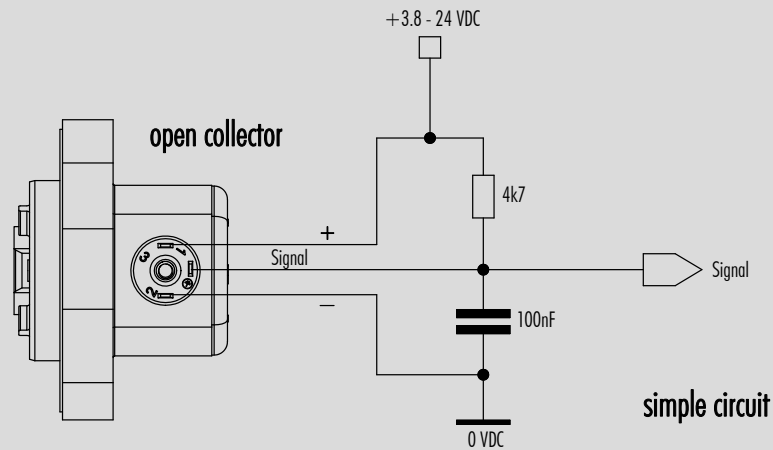

Measurement Curve FF PVDF Ø6.00 mm 4 Magnet

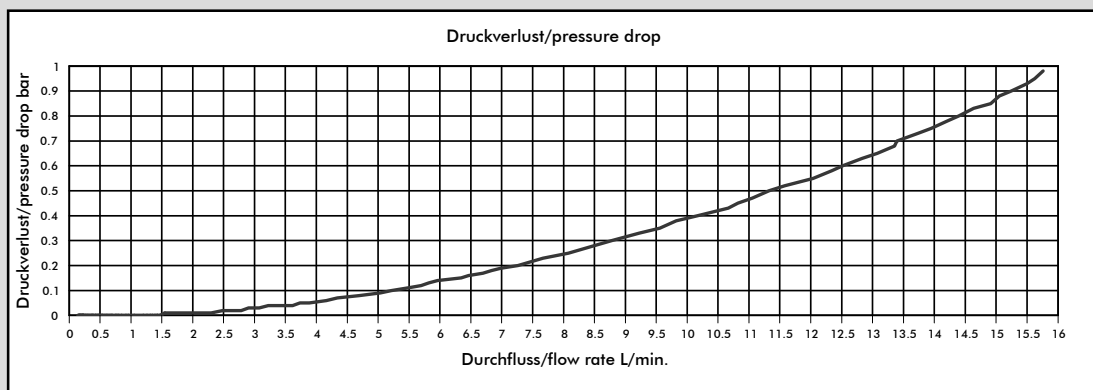
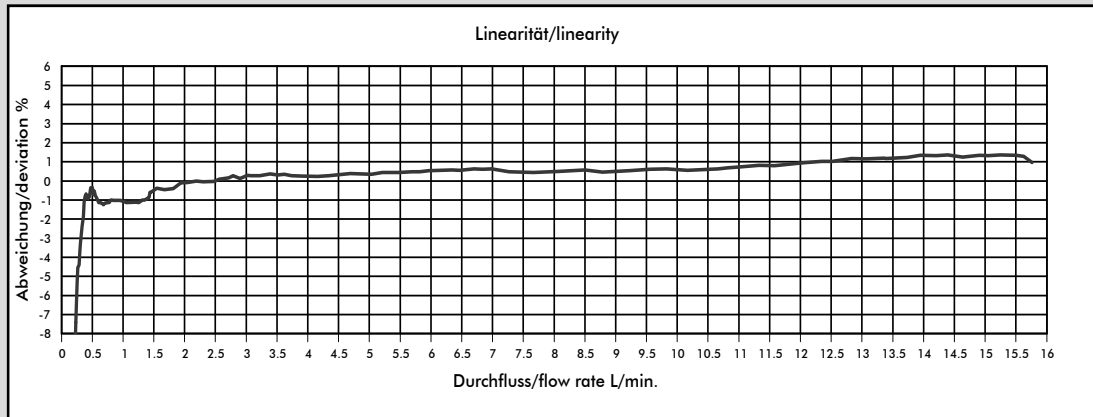

Medium Wasser / max. Druck: 3.3 bar

Nozzle size	Pulses/litre	g/pulse	min. flow rate in [litres/min] at linear start	max. flow rate in [litres/min]	Pressure loss in [bar]
Ø 6.00 mm	382	2.6	0.35	15.75	1.0

MEASUREMENT TIPS

- Ensure that there is no fast-pulsatory movement of the media
- Ensure that there are no reverse pressure surges
- Ensure that there is no air in the system
- Keep the pressure loss as small as possible
- Note the mounting position of the flowmeter
- Min/max flow should be in the linear range of the selected flowmeter
- Clean the system at appropriate intervals
- Avoid electrical current peaks
- Incorrect cabling of power supply +, signal and ground will destroy the flowmeter
- Do not mechanically load electrical contacts
- Avoid moisture on the electrical contacts
- Avoid stray pick-up via the cable (Do not lay cables in parallel with high current loads)

The values specified must be considered as approximate values.

The number of pulses per litre may differ depending on medium and installation.

We recommend to calibrate the number of pulses per litre in line with the complete installation.