

# FCD II & FCD 3

## Operating manual

### Table of contents

Safety rules .....	3
1 Introduction .....	4
2 Versions .....	4
2.1 Contents of packing (standard version) .....	5
3 Installation .....	5
3.1 Electrical connection .....	7
<b>3.1.1 Flowmeter .....</b>	<b>7</b>
<b>3.1.2 Power supply .....</b>	<b>8</b>
4 Preparation .....	8
4.1 Front panel .....	8
4.2 Keyboard .....	9
4.3 Operation (FCD-II only) .....	10
4.4 Working mode (FCD-II only) .....	10
4.5 Indicator of empty keg (FCD-II only) .....	11
4.6 Master key (FCD-II only) .....	11
4.7 Host mode (FCD-II only) .....	11
<b>4.7.1 Programming litre calibration (FCD-II only) .....</b>	<b>12</b>
<b>4.7.2 Programming the portion size (FCD-II only) .....</b>	<b>12</b>
4.8 Setting to zero (FCD-II only) .....	13
4.9 Re-calibration (FCD-II only) .....	13
4.10 Cleaner key (FCD-II only) .....	14

The logo for Digimesa, featuring the word "Digimesa" in a bold, italicized, sans-serif font. The letter "i" in "Digimesa" has a small graphic element resembling a stylized flame or a drop above it.

Digimesa AG, Keltenstrasse 31, CH-2563 Ipsach / Switzerland  
Phone +41 (32) 332 77 77, Fax +41 (32) 332 77 88  
[www.digimesa.com](http://www.digimesa.com)

4.11 Clock setting (FCD-II only) .....	14
4.12 Date setting (FCD-II only) .....	14
5 Troubleshooting .....	15
6 Specifications* .....	16
7 Appendix .....	17
7.1 Assembling an extra module .....	17
7.2 How to change a module .....	18
7.3 Location of the fuse .....	18
Software addition FCD-III .....	19
1 General Operation .....	19
2 Cleaning (CLEAN-Dallskey) .....	20
3 HOST - Mode (Master-Dallskey) .....	20
4 Counters / resetting counters .....	20
5 Calibration .....	21
6 Parameter settings .....	22
7 Date settings .....	22
8 Data inquiry via interface .....	22

The user is not entitled to indemnities for possible technical imprecisions or misprints present in this manual.

This manual may be modified without forewarn.

## Safety rules

1. Read through the instructions before you put the FCD-II into operation. Follow all the operations according exactly to the directions for use.
2. Keep to the directions for use and to the indications that may appear on the FCD-II.
3. Cut off power supply before opening the connection cover or unscrewing the front panel.
4. The FCD-II is protected according to the safety rules IP65, i.e. it is protected against sprays of water, but only if the transparent cover is closed.
5. The voltage must agree with the values written on the label on the back.
6. The FCD-II is provided with a terminal for the earthwire. The grounding must be absolutely connected.
7. The FCD-II should not be put into operation without the connection cover (danger of wounding if the electronics is touched).
8. Cut off power supply and call a technician if one of the following cases occurs:
  - if water or other fluids have entered the FCD-II.
  - the FCD-II doesn't work correctly even though you have followed all the instructions given. Do not try to change anything on your own; do not press any key trying to get some reaction.
  - if the FCD-II falls down and the box is damaged.

# 1 Introduction

The FCD-II is a precise control system with the most modern microprocessors.

The quantity of fluids, that passes through the installation is constantly measured. Bar keepers don't have to change their habits: the FCD-II corrects the intertias present inside the flowmeter automatically.

The FCD-II has several counters that can be questioned at any time. Each pipe can be calibrated precisely according to its use (i.e. according to the drinks that have to be measured: beer, mineral water, pre-mix, etc...).

The access to special functions on the flow computer FCD-II is possible only by using intelligent keys.

The FCD-II signals whenever a keg is empty by using a flowmeter provided with foam detection. Also in the standard version a relay is available with which further alarm systems can be connected.

## 2 Versions

The FCD-II is available in the following versions:

- control of four pipes, art. no 923-9104 (standard version)
- control of eight pipes, art. no 923-9108
- control of twelve pipes, art. no 923-9112
- control of sixteen pipes, art. no 923-9116

The FCD-II can be equipped with additional modules. Four additional pipes per modules can be added. The FCD-II can contain no more than four modules (i.e. 16 pipes).

## 2.1 Contents of packing (standard version)

- 1 FCD-II
- 2 cable inlets PG11 (art. no 699-0003)
  - one for the power supply cable 230V ( 3 wires with min. section of 0.75mm<sup>2</sup> and external diameter 6.80mm)
  - one for four flowmeter cables (external diameter max. 4mm).
- 1 cable inlet PG9 (art. no 699-0002) used for the cable of the serial interface RS-485.
- 1 intelligent key with the black ring (master key) art. no 990-0002
- 1 intelligent key with the silver ring (cleaner key) art. no. 990-0000
- 1 manual art. no 823-1001

## 3 Installation

Choose a suitable place for the FCD-II and keep to the following instructions:

- the unit has to be easily reached.
- the unit has to be put at a comfortable height.
- the place has to be well illuminated (the display has no rear light)

Choose whether to install the cable inlets on the rear side or on the bottom side of the FCD-II box.

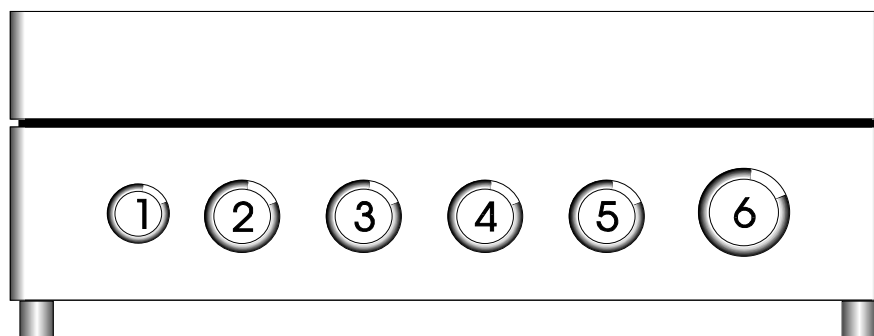

*Bottom side*

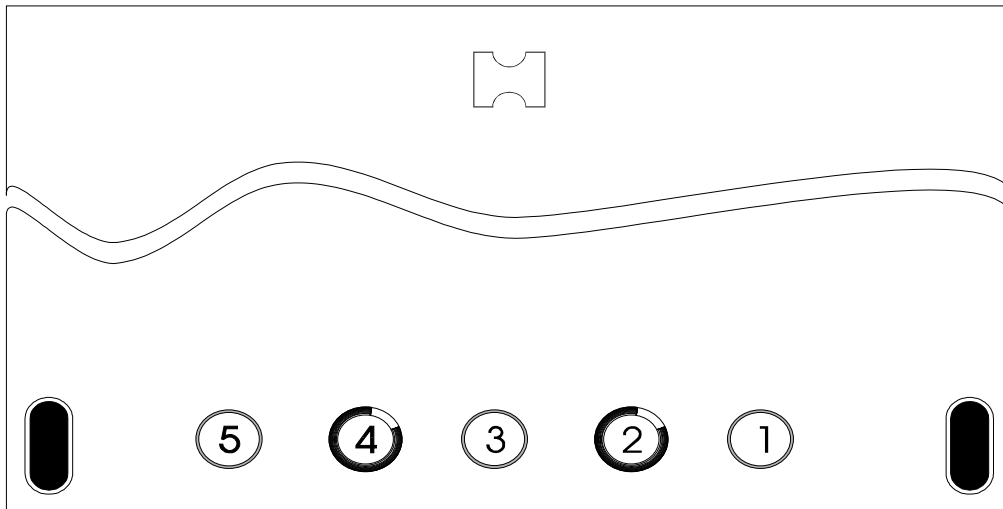

*rear side*

Cut out as many holes as you need on the side chosen by using a screwdriver and a hammer. Take one of the cable inlets PG-11 in order to connect the first group of the four flowmeters. Unscrew the nut and put the screw into the corresponding hole and fix it. Then install the second cable inlet PG-11 for the 230 V cable. If you need an interface, install the cable inlet PG-9 as well.

Place the FCD-II as follows:

Fix a screw into the wall and hang the FCD-II on it. Open the connection cover. For additional safety of the unit, two more screws can be fixed on its corners.

## 3.1 Electrical connection

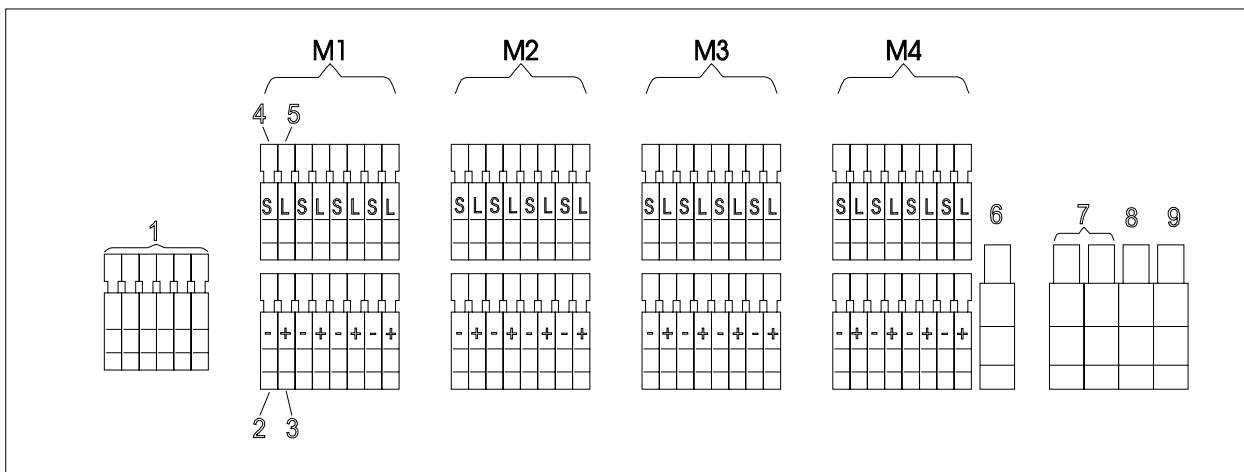

*diagram connection*

### Legend

- 1 = serial interface RS-485
- 2 = negative pole "-" on Flowmeter 2
- 3 = positive pole "+" on Flowmeter 1
- 4 = signal on Flowmeter 
- 5 = empty keg indicator on Flowmeter 3
- 6 = connection for a flowmeter group
- 7 = earthing
- 8 = additional relay connection for empty keg indicator
- 9 = power supply neutral
- 10 = power supply phase

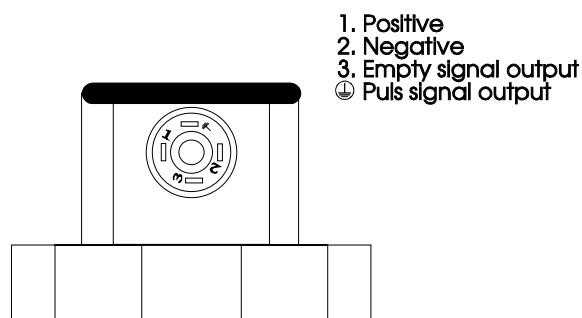

### 3.1.1 Flowmeter

Number progressively each cable of the flowmeters which will be connected to the FCD-II. Insert the cable of the first flowmeter into the corresponding cable inlet. Take off the cable insulation for about 5 cm and strip each wire (about 5mm).

Put each wire of the first flowmeter into the terminal as follows:

Press the white lever by using a small screwdriver (no 0 or no 1). At the same time, insert the wire into the terminal. Release the lever.

Connect the flowmeter wires as follows:

- green wire = terminal „-“ on Flowmeter 2
- brown wire = terminal „+“ on Flowmeter 1
- white wire = terminal „S“ (signal) 
- yellow wire\* = terminal „L“ (empty key indicator) on Flowmeter 3

\*Not all flowmeter models dispose of a foam indicator.

Repeat this operation for each flowmeter.

**Note:** the wire colours listed above are a DIGMESA-code and can be changed.

### 3.1.2 Power supply

Insert the 230V cable ( a 3-pole cable with a section of 1,5mm<sup>2</sup> is recommended) into the cable inlet. Take off the cable insulation for about 5 cm and strip each wire (about 5mm).

Connect each wire as follows:

Phase = orange terminal

Neutral = blue terminal

earthing = green terminal

Close the connection cover, connect the flowmeters and turn power on.

## 4 Preparation

Before operating the FCD-II, note that:

- Text written in *italics* represents a message on the display.
- Text written in **bold** refers to the keyboard.

### 4.1 Front panel

1. LED indicator (empty key indicator).
2. LCD display
3. Keyboard
4. intelligent key socket
5. Connection cover

## 4.2 Keyboard

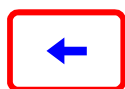
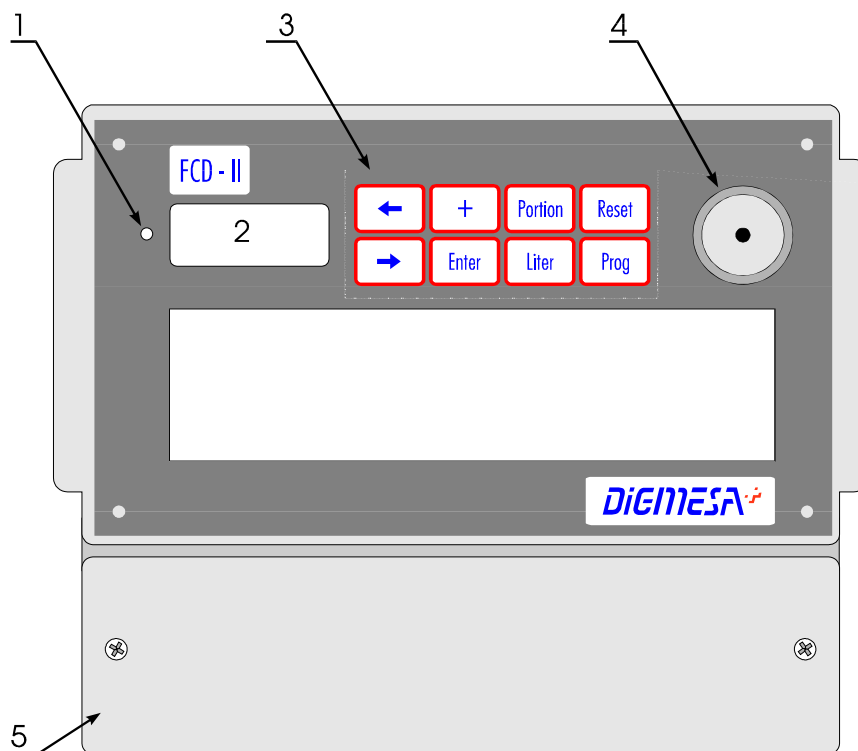

to the previous line

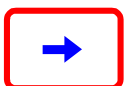

to the next line



confirm entry



entering the values in programming mode



program/examine the portion size



program/examine litre calibration



setting to zero



go to programming mode

## 4.3 Operation

**NOTE FOR FCD-III USERS** : the following chapters (4.3 to 4.12) are only valid for FCD-II. Please go to page 19 'Software addition for FCD-III' !

As soon as the tension is connected, *FCD-2* will appear on the display. If no button is pressed for about one minute, the clock will appear on display.

## 4.4 Working mode

Any lines can be reached by pressing <- or ->. The display will show automatically the first line just after the selection of the last one. The number of lines connected to the unit can be controlled as well.

As soon as the requested line is displayed, press the Enter button. The unit will show either *nodEF* (not defined) if the line is not programmed yet, or it will show the quantity in litres or in portions.

At the very bottom of the display it will be indicated whether the quantity is expressed in litres or in portions. There are two different litre counters:

Litre flag flashes = shows the quantity poured out of the connected keg.  
This counter can be set to zero by pressing the **RESET** button at any time without the master key (intermediate counter).

Litre flag normal = shows the quantity poured out of the line. This counter can be set to zero only by pressing the **RESET** button using the master key. (global counter)

Portion flag = shows the number of portions poured out. This counter can be set to zero only by pressing the **RESET** button using the master key.

By pressing the **ENTER** button, you can go to the next counter. The FCD-II displays per line only what is programmed. Examples:

- If nothing is programmed in the correspondent line, *nodEF* will appear on the display.
- If it is programmed only in portions, only the portion counter will appear.
- If only the liter calibration is programmed, only the two-litre counters will appear.
- if both values are programmed, the counters will appear in this order: intermediate counter, portion counter, global counter.

## 4.5 Indicator of empty keg

As soon as the signal „no more fluid in the line“ comes from the connected flowmeter (which must have four pins), the red LED (1) lights up on the FCD-II. When the unit is in standby mode (it displays the clock), the correspondent line number will be displayed as *AL-XX* where *XX* represents the line number.

If you are working on the FCD-II and the LED lights up, it means that one or more kegs are empty. You can finish up normally. Now reach one line after another by pressing the arrow buttons. The lines which are empty will appear and begin to flash.

You can also use the additional relay connection to drive an external alarm (for ex.: a lamp, a horn, etc... ).

## 4.6 Master key

When the master key is put on its socket for the first time, you will hear three beeps and the message *HOS*t will appear on the display. From now on, you will hear only one beep when you put the master key.

Only one master key per FCD-II is valable. If the master key of the FCD-II gets lost, another one can be bought. As soon as the new key is put on the socket, only this one will be right for this unit.

As long as the master key remains on the socket, you have access to all features of the unit:

- setting all the counters to zero.
- programming of the litre and the portion calibration.
- continuous flow monitoring.

All lines have to be programmed before FCD-II is ready to work. Otherwise, some errors in the data can occur.

## 4.7 Host mode

Put the master key on the socket to enter the host mode. The FCD-II has two calibration values per lines: one for litres and one for portions.

## 4.7.1 Programming litre calibration

Choose one line by using the arrow button. Then press the **PROG** button. Now the number of pulses per litre is displayed (max 32,766 pulses/litre) depending on the flowmeter mounted in the pipe (for ex.: FFB-50 = about 240 pulses/litre; FFC-40 = about 335 pulses/litre). You can programm this value in two ways:

### 1st possibility

Modify directly the value. Press the **RESET** button, in ordre to set this value to 00000. By using the arrow buttons, you can choose the digit that you want to change (the chosen digit flashes). The digit can be changed by pressing the + button. Number 0 appears after number 9. If the + button is pressed continuously, the digit will change its value automatically. Release the button as soon as the requested number is reached. Press the **ENTER** button to confirm. The display will show the line number which has been programmed.

### 2nd possibility

The FCD-II can be programmed even when the number of pulses is not known. When the number of pulses is displayed, press **LITER** and then **PROG**. A little horizontal dash appears on the display. Any quantity of liquid (at least 0.5 l. ) can now be poured out of the tap. Meanwhile the little dash moves. When the requested quantity is poured out, press **ENTER**. By pressing the + button and the arrow keys set the poured quantity in litres (for ex.: 00.760). Press **ENTER** to confirm otherwise press the **PROG** button to start again. Press the **LITER** button to check up the litre calibration. The pulse/litre measured appears on the display for two seconds.

## 4.7.2 Programming the portion size

To program the portion size, it is important to consider that:

If the litre calibration is set to zero, the portion size can not be given in litre but only in pulses.

### 1st possibility (litre cal. = 00000)

Choose one line. Press **PROG** and then **PORTION**. By pressing the arrows and the + button set the number of pulses which correspond to the requested portion. Press **ENTER** to confirm.

### 2nd possibility (litre cal. is set)

Choose one line. Press **PROG** and then **PORTION**. By pressing the arrows and the + button set the portion size in litres (for ex.: 00.300 = 3dl = 300ml). Press **ENTER** to confirm.

3rd possibility (litre cal. = 00000)

Choose one line. Press **PROG** and then **PORTION** and then **PROG** again. A little horizontal dash will appear on the display. Now pour the requested portion out of the tap. Meanwile the little dash moves. As soon as the portion is poured out, press **ENTER** to confirm. The measured number of pulses appears on the display. If everything is all right, press **ENTER** to confirm, otherwise press **PROG** and start again.

4th possibility (litre cal. is set)

Choose one line. Press **PROG**, then **PORTION** and then **PROG** again. A little horizontal dash will appear on the display. Now pour the requested portion out of the tap. Meanwile the little dash moves. As soon as the portion is poured out, press **ENTER** to confirm. The measured portion in litres appears on the display. If everything is all right, press **ENTER** to confirm. If the requested quantity is not exact, it can be corrected by using the keyboard (for ex.: poured quantity = 00.276 real portion size=00.300).

**Note:** the reference of the FCD-II is pulses. When the portion size is given in litre, the FCD-II will approximate this value according to the litre calibration.

Example:	Litre calibration	=	244
	Portion size	=	00.300 litre
	Portion pulses	=	$244 \times 0.3 = 73.2$
	reference number	=	73
	rounded portion size	=	$73 : 244 = 00.299$

Once the programming of every line is completed, take out the key.

## 4.8 Setting to zero

Put the master key on the socket and choose a line using the arrows. Once reached the requested line, press the **ENTER** button. Go to the requested counter by pressing the **ENTER** button. By pressing **RESET**, the value will be cleared to zero. After setting all the requested lines to zero, take out the key.

## 4.9 Re-calibration

If, for example, a 50-litre keg is emptied but the value on the display does not correspond (for ex.: 47 litres), this value can be corrected as follows:

- choose the requested line by using the arrow buttons.
- press the **PROG** button and then the **LITER** button: the display will show the global counter (litre counter).
- correct this value to the actual one by using the + button and the arrows
- press **ENTER** to confirm.

## 4.10 Cleaner key

The FCD-II has a special function to clean the pipes. Put the cleaner key on the socket, you will hear two consecutive beeps and *CLEAN* will appear on the display. The key has to be kept on the socket during the entire cleaning and will be taken away at the end of it. The counters do not change during the cleaning.

## 4.11 Clock setting

Clock setting is possible only if the FCD-II is in standby mode. Press the **PROG** button first, the minute indicator flashes. Keep pressing the + button as long as you reach the right number. By pressing the arrow button, you can reach the hour indicator. Set the hour by pressing the + button. Press **ENTER** to confirm.

## 4.12 Date setting

Put the master key on the socket and wait until the FCD-II go into the standby mode (about 1 minute). Press the **PROG** button first, the minute indicator flashes. Press the **ENTER** button if you want to bypass the clock setting. The year will be shown. You can modify it by pressing the arrow and the + buttons. Press the **ENTER** button to confirm. *Mt* (= month) and *Dt* (=date) will appear consecutively on the display. You can modify these values by pressing the + button. Press **ENTER** to confirm each one. Then the clock will appear on the display. Take out the master key.

## 5 Troubleshooting

The indicator is empty

- a) check the power supply
- b) check the connection between the main and the front print
- c) check the fuse (see schema 7.3.)
- d) call a technician

A flowmeter group does not work

- a) check the cables of each flowmeter (reversed polarity)

The empty keg indicator flashes without reason

- a) exchange the wire of the signal indicator with that of the empty keg indicator

The display shows incomprehensible values

- a) cut off power supply for 10 seconds
- b) call a technician

## 6 Specifications\*

Power requirement :	230V~ / +/- 10% 50-60Hz (115 V~ 50-60Hz at request)
Power consumption:	max 5 Watt charged with 16 flowmeters
Temperature tolerance	
operating:	-10°C to +70°C
storage:	-20°C to +70°C
Measure functions:	3 pulse counters per line (32 bits)
Display functions	
intermediate counter:	0.01 to 99,999 litres with automatic range selection
global counter:	0.1 to 99,999 litres with automatic range selection
portion counter:	1 to 99,999 portions
Display:	5 digits LCD display
Keyboard:	10-key keyboard
Memory:	Battery backed-up memory (10 years)
Flowmeters:	All the DIGMESA flowmeters. The Sm flowmeters (4 pins) are specially suitable to work with the FCD-II. It permits to monitor the empty kegs.
Inputs :	16 flowmeter inputs divided into four modules.
Outputs:	one relay contact max. 6Amps / 230V~
Interface:	1 RS-485 interface.

\*technical modification rights reserved.

## 7 Appendix

### 7.1 Assembling an extra module

When you order an extra module to monitor four extra flowmeter lines, the package will contain:

- 1 cable inlet PG 11, for 4 flowmeter cables ( 4mm diameter).
- 1 module

Follow the procedure below to mount the module on the FCD-II.

- cut off power supply.
- unscrew the connection cover.
- assemble the cable inlet as described in § 3.
- connect the cables with the FCD-II (§ 3.1.1.)
- unscrew the front panel.
- take out carefully the plug from the front print.
- put the module on the next free 30-pole socket which corresponds to the flowmeter group. Press the module down and turn until it remains fixed vertically.

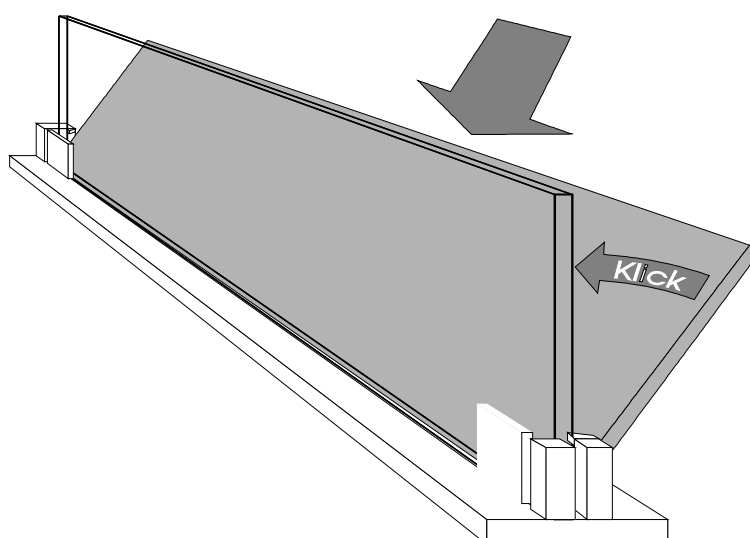

- connect the plug with the front print again.
- fasten the front panel.
- fasten the connection cover.
- turn power on.
- go through every line by using the arrow keys. Check if the new module is recognized. If everything is all right, the new 4 lines will appear on the display.

## 7.2 How to change a module

Open gently both lockings which are located at the extremities of the connector, turn the module down and take it away.

## 7.3 Location of the fuse

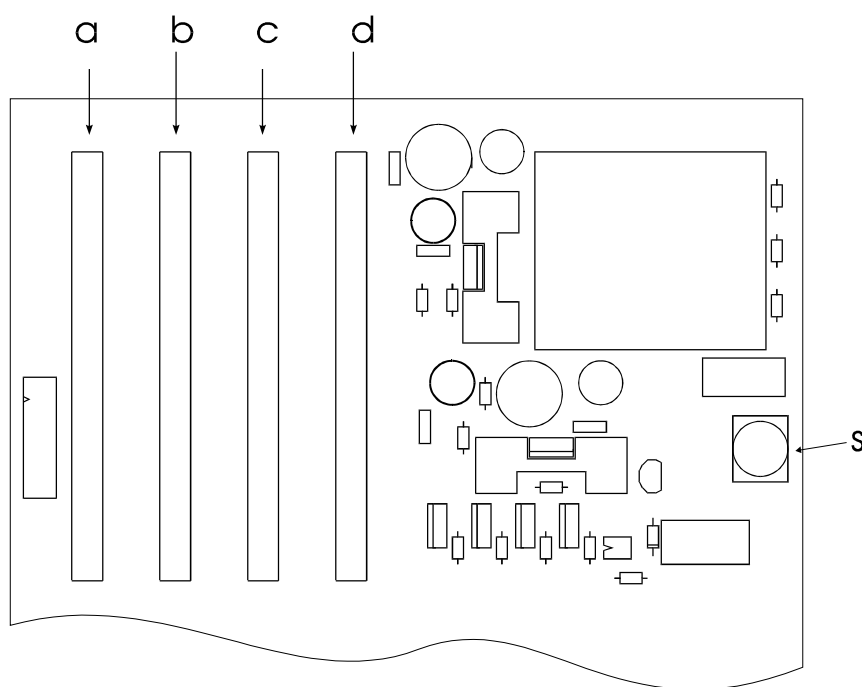

### legend

- a = module 1 (flowmeter 1 to 4)
- b = module 2 (flowmeter 5 to 8)
- c = module 3 (flowmeter 9 to 12)
- d = module 4 (flowmeter 13 to 16)
- s = fuse holder



# SOFTWARE FCD-III

## Addition of the operating instructions FCD-II

In the context of the technical progress our FCD-II received a more modern microprocessor as well as a completely new designed system software. Since in terms of hardware for the user did not change anything, the past manual of FCD II keeps its validity.

What has changed, is the operation of the equipment. This is described in detail in this appendix to the FCD-II manual. Furthermore, the data exchange protocol has also changed. You experience more information in addition in chapter 8 of this auxiliary documentation.

### 1 General operation

After switching on the power, the device announces itself with display and sound check; and thereafter it will display the installed **version number** for a certain time. To get the version number from already running device, you can **restart** the device by pressing simultaneously the keys  +  + 



The display shows alternating the selected line number and the corresponding counter reading. If **Error** is displayed in place of a value, then this value is greater than **99999** and cannot be displayed. Big values can only be accessed via the serial interface. Internally, the range is limited to 4294967295 impulses, that means, a flowmeter with a calibration value of 240 Imp/Lt. will count up to 17,9 mill. litres and then will continue at zero.





As function control, the **LED** blinks periodically briefly. If a data communication takes place, then this flickers during the time of the data communication; simultaneous a gnashy noise is to be heard. This serves for the simplified error tracing in case of difficulties during the data communication.



If you use **measuring instruments with integrated empty detection**, thus the LED goes into steady light as soon as one of the attached measuring instruments is empty. At the same time, the display changes on the corresponding line to alternating: **L 1 03 > ALERt > 0 1247** (example: Line 3 Alert). If at least one of the lines is empty, then also the relay is switching with a defined debounce time (**Conn. AUX** - closing contact).

With the keys   you **select the line** which will be indicated.

With  you alternate the display between **totalcounter** () and **splitcounter** ( flashing).

With the key  the **portioncounter** is indicated. The key  alternates between **time indication** and the selected counter announcement. The **date** is periodically represented during time indication as scrolling text.

You can **adjust the time** (not however the date) without masterkey: change on time indication and press  (the minutes blinks now), then adjust the value with  and change between minutes and hours with  or . Terminate with .

If the parameter settings allows, you can **reset the splitcounters** without masterkey: change to the desired line and make sure that the splitcounter is displayed ( flashing). If it's allowed, the display will show ' **rESEt** ' by pressing the key . After 4 seconds of continuous actuation, the splitcounter of the selected line will be set to zero with acoustic acknowledgement. For this, you receive more information in chapters 4 and 6.

## 2 Cleaning (CLEAN-Dallaskey)

At an FCD, as many as desired **cleaning keys** can be used ; one is delivered in each case. However, **additional** cleaning keys with **individual key numbers** can be ordered at any time. Simply apply the cleankey to the support plate and the display announces ' **CLEAn** ' blinking. After some seconds, the unit beep's twice and the flashing announcement change to statically. Starting from this time, the cleaning is activated and registered in the internal **cleaning diary** . For the duration of the cleaning process, litres- and portion counters are suppressed. Each line is documented with its own **cleaning counter** , how many litres actually flowed through with the respective cleaning. If the cleaning key is removed, the announcement changes again to blinking; after a few seconds, a threefold beep appears and the display change into the normal mode; the cleaning is terminated. The ten last cleanings are stored internally constantly and are, if necessary, **accessible via the serial interface** (starting time, stop time, keynumber, quantities).

## 3 HOST - Mode (MASTER-Dallaskey)

For all further functions than the already described you must change first into the **host mode**. Set for this the provided **MASTER Dallaskey** on the support plate. This keys are **individual**, i.e. a master key can **be used only at it's associated device**. Thus pay attention if you operate several FCD's in your installation. Newly delivered keys are not assigned yet. By putting the key the first time on, the device recognizes a **new key** automatically and assigns it themselves irrevocable . Master keys possibly **assigned in former times** are defined thereby as **to be invalidly** from now on. Once assigned to a certain FCD, the master key cannot be made valid for another FCD, except it will be sent back to DIGMESA for reinitialization. If you put a **new key** on the first time, then the FCD will acknowledge this after a few seconds with a **threefold beep**. If the key is **already assigned to this FCD**, then a **unique beep** appears. The display shows for one moment : ' **HOST** '. If the key is **already assigned to another FCD**, then nothing happens (invalid key).

## 4 Counters / resetting counters



The FCD's have by default **four counters each line**; three are directly editable:

- 1 : Totalcounter (editable)
- 2 : Splitcounter (editable)
- 3 : Portioncounter (editable)
- 4 : Cleningcounter (not editable)



Counters 1, 2 and 4 contains a common **calibration factor** (pulses per unit) during counter 3 (portions) his own factor possess. You can use it as freely calibratable portion counter like also for indicating consumption in another unit (gallones(US/GB)Quart etc.) or for example a price, so that the computational amount can be read out directly without converting, as portion counter : E.G. 1 litre product corresponds to 224 impulses per litre - 1 litre costs 3,45\$ = (224: 3,45) 65 impulses per \$.



Counters 1 and 3 can be resetted only in the host mode, while for counter 2 (splitcounter) it can be intended whether he may be resetted without masterkey or not. (see chapter 1 and 6)  
Counter 4 serves for the documentation in the cleaning diary and is not influenceable.

Resetting counters in the HOST-Mode :

Put on the Masterkey, then select first the desired line with  

Splitcounter : hold  for 4 seconds









Totalcounter : hold  and  for 4 seconds

Portioncounter : hold  and  for 4 seconds

The procedure is acoustically acknowledged.

## **5 Calibration (HOST Mode only)**

Flowmeters delivers differently amounts of **impulses per litre**; dependent mainly on the **nozzle size** and the **viscosity** of the measured medium . Therefore it is necessary to calibrate all lines before the operation.

Different methods are to you at the disposal. If you already know the number of delivered impulses per litre, then you can use the **manual calibration** : put on the masterkey and select the desired line with  and  . Press the keys  or  at the same time, depending whether you would like to calibrate a litre or a portion. **Ex factory preset**, the display shows now **00240** or the last adjusted value. With the keys   you select the decimal place which can be edited (this blinks) and with the key  you adjust their value. Terminate and assume the value with  .





**Breaking off** a begun calibration is at any time possible **by removing the masterkey**.

**NOTICE** : A change of the calibration affects immediately the counter reading, since **the actual impulses** and not the calibrated quantities are cumulated internally!

**Automatic Calibration** : begin as with manual calibration until the display shows the actual calibration value and press 4 seconds  . The display indicates : **A0000** . ('A' blinking)







**NOTICE** : An automatic calibration procedure sets previous the respective total counter to zero, not however the other counters. The taken quantity per procedure is credited thereafter to all counters of this line.

There are **two measuring possibilities** available; **1:** You extract **exactly 1 litre** product into a measuring beaker. The display shows the number of measured impulses. Terminate and assume the adjustment with  .

In addition, you can do **2:** extract **any quantity** into a tared container and this thereafter **weigh** or filling partly a measuring beaker. In place of ENTER you press  . The display will show now **10000** ; with   and  you have to change the value in accordance with the level of the measuring beaker or the weight in kilograms. The **1:1 input of kilograms** works satisfactorily with **most usual beverages**. For products with strikingly **different density** than water (oils, etc..) **converting** into litres is however recommended in accordance with their **specific weight**.

**NOTICE** that, **as larger as the calibrated quantity is**, as **more exact the long-term measurement** will be.

In order to obtain a **very exact calibration value**, you have the possibility of a **recalibration**.

**NOTICE** that a recalibration always is oriented at the counter reading of the total counter. As example for a successful recalibration we make use of a keg beer with 30 litres contents : attach the absolutely new keg and set the total counter to zero. If the keg becomes empty, re-elect  and thereafter press 4 seconds  . The display shows now the value measured so far, e.g. **28439** . Adjust now the correct value ( **30000** ) with   and  . Terminate and assume the value with  . You can use this feature also from the beginning of initial operation, since with the automatic calibration, the total counter will be set to zero and the extracted quantity from calibration is already credited to the total counter. You must start thus only with a new container .

## 6 Parameter settings (HOST Mode only)

The FCD-III software contains 3 operating parameters since version 1.00, which are described in the following. Possibly newly added parameters on higher OS-Versions will be separately documented.

The fundamental editing steps itself will remain the same however : change into HOST-Mode (Masterkey) and press **Prog** for 4 seconds. With the keys **←**, **→** you can choose the desired parameter, with the key **+** you can change it's value and with the key **Enter** you quit the parameter-editing mode. Note, that in this mode an abort is not possible by removing the master key; changes are directly valid.

The parameters and their effects are :

<b>dt</b>	date & timemode	:	<b>EU</b>	europaean	/	<b>US</b>	american
<b>St</b>	automatic summertime	:	<b>y</b>	yes	/	<b>n</b>	no
<b>rES</b>	reset of splitcounter allowed without masterkey	:	<b>y</b>	yes	/	<b>n</b>	no

## 7 Date setting (HOST Mode only)

The FCD-III software contains an extensive time and date system. It is appropriate for the use in Europe as well as for the American continent. The display changes as follows :

European : 24 hours, TT/MM/JJJJ      American : 12 hour AM:PM, MM/DD/YYYY

The leap year compensation happens automatically. Further it can be adjusted whether an automatic summer- wintertime compensation is to take place or not. This happens depending upon time zone adjustment (EU/US) at the respective fixed dates. **NOTE** that with activated summer time compensation during spanning date adjustment, the time will automatically adjusts without further inquiry.

Thus during setting up, first adjust of the date and afterwards of the correct time.

(Parametersettings see chapter 6; time settings chapter 1)

Date setting : put on the masterkey and press **Enter** , the display shows now the year.

Edit the year with the keys **←** , **→** or **+** ; terminate with **Enter** . The display shows : **nt** (month)

Edit the month the same way like the year and terminate with **Enter** . The display shows : **dt** (date).

Edit the date the same way and terminate with **Enter** . The date setting is now completed.

## 8 Data inquiry via interface

The FCD's have alternatively a RS-232 or a RS-485 interface (has to be indicated at the order) with the objective to exchange datas with an superordinate device. If only one FCD shall to be connected to another device (PC, countersystem etc.), RS-232 is the best solution, since no peripheral interface adapter is needed. However, if several FCD's have to communicate at a single connection, then RS-485 is obligatory. In this case, each FCD must be configured with an unique device number, which is adjustable via jumpers. Details for this see in the main manual to FCD-II.

The protocol of FCD-III **is no longer compatible** to the protocol of FCD-II. However, existing software can be made compatible without larger expenditures. Detailed documents and support to this you will receive upon request by our development department.

Upon demand, there is also a Windows PC software available, with which the FCD III's can be read out and get configured easily. This contains also an export function to transfer datas into free configurable cell's in an EXCEL table.



***DIGMESA*** 

Digimesa AG, Keltenstrasse 31, CH-2563 Ipsach / Switzerland  
Phone +41 (32) 332 77 77, Fax +41 (32) 332 77 88  
[www.digimesa.com](http://www.digimesa.com)